

Strangkühlkörper

Extruded heatsinks

Dissipateurs extrudés

### SK 174

75 1000 mm

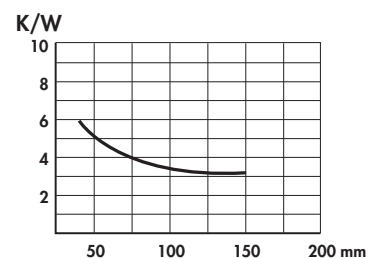
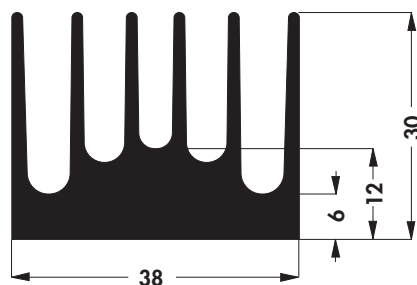

Strangkühlkörper

Extruded heatsinks

Dissipateurs extrudés

**SK 472**

↔ 37,5 50 75 100 1000 mm

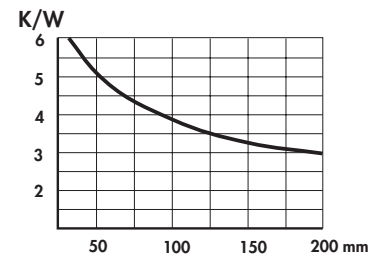
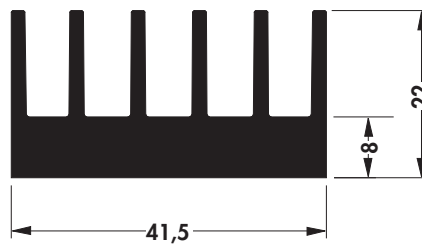

Strangkühlkörper

Extruded heatsinks

Dissipateurs extrudés

**SK 422**

↔ 50 1000 mm

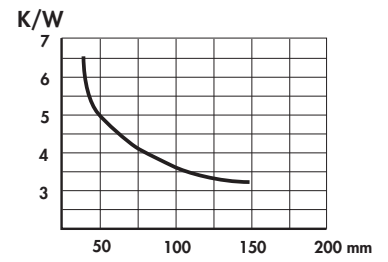
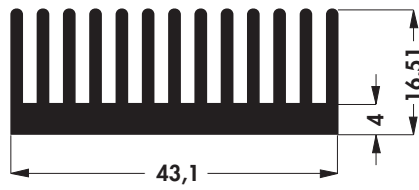

|                         |                           |                              |
|-------------------------|---------------------------|------------------------------|
| <b>Strangkühlkörper</b> | <b>Extruded heatsinks</b> | <b>Dissipateurs extrudés</b> |
|-------------------------|---------------------------|------------------------------|



**SK 156**

↔ 37,5 50 75 100 1000 mm

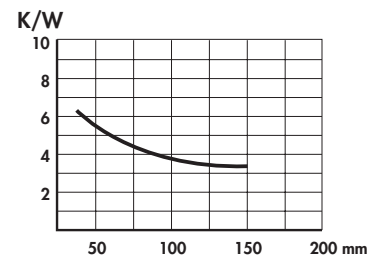
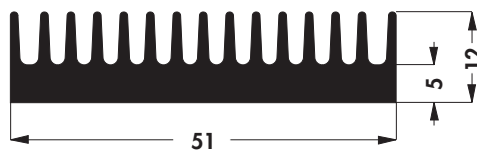

Strangkühlkörper

Extruded heatsinks

Dissipateurs extrudés

**SK 180**

↔ 37,5 50 75 100 1000 mm

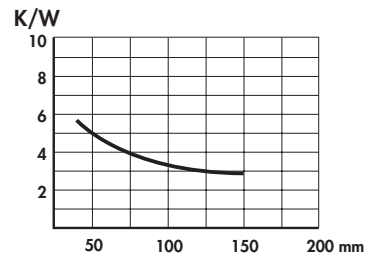
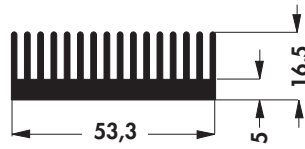

Strangkühlkörper

Extruded heatsinks

Dissipateurs extrudés

**SK 78**

37,5 50 75 100 1000 mm

TO 3    CB

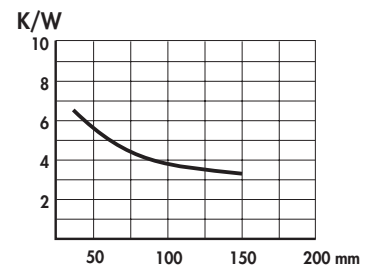
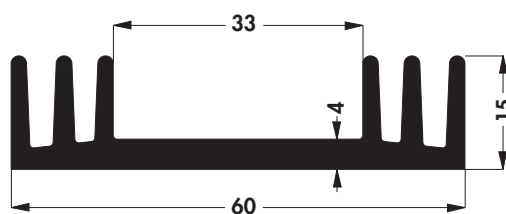

Strangkühlkörper

Extruded heatsinks

Dissipateurs extrudés

### SK 150

1000 mm

TO 3    CB

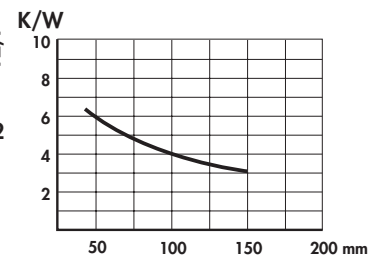
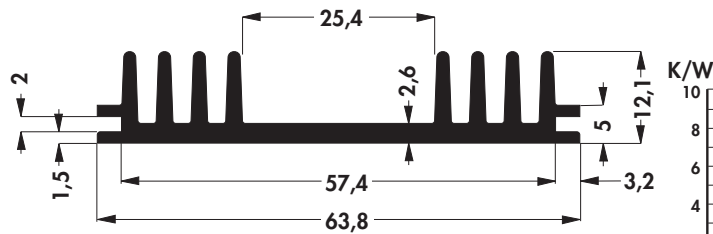

**Spezialkühlkörper**

**Special heatsinks**

**Dissipateurs spéciaux**

**SK 171**

↔ 84 100 1000 mm

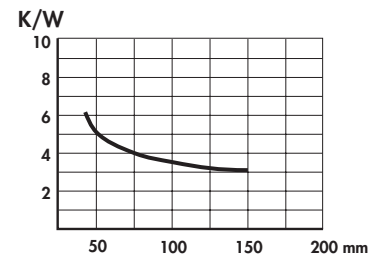
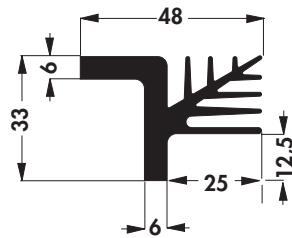

**SK 173**

↔ 1000 mm

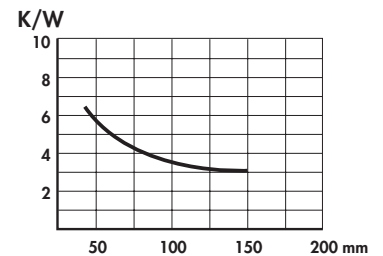
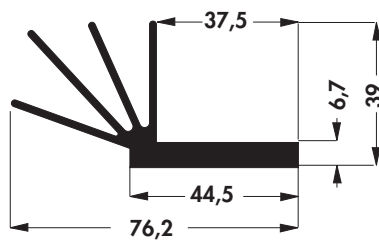



Spezialkühlkörper

Special heatsinks

Dissipateurs spéciaux

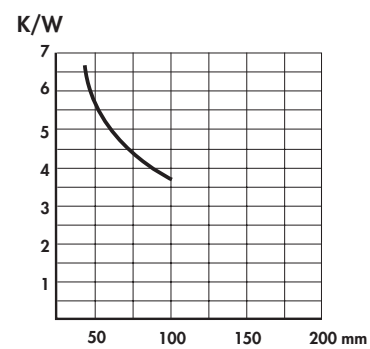
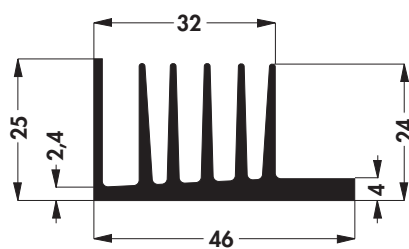

**SK 107**

↔ 50 75 100 1000 mm

**Kühlkörper zur Verwendung auf Europakarten**

**Heatsinks for application on eurocards**

**Dissipateurs pour application sur cartes euro**

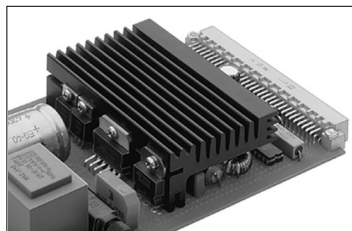

**SK 96**

84 1000 mm  
3,6 K/W

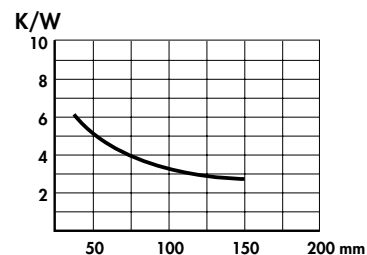
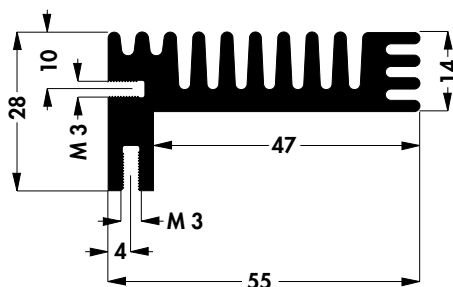

**SK 138**

84 1000 mm  
3,9 K/W

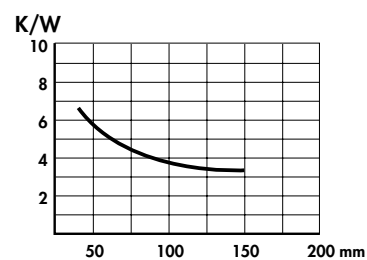
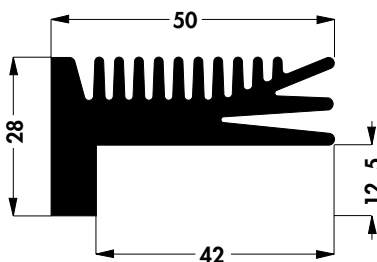

**SK 451**

84 1000 mm  
4 K/W

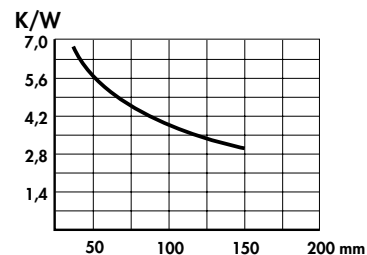
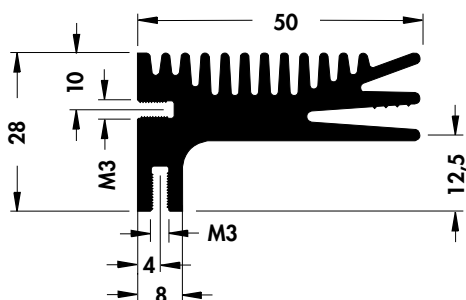

**SK 128**

1000 mm

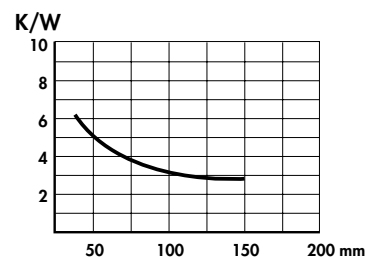
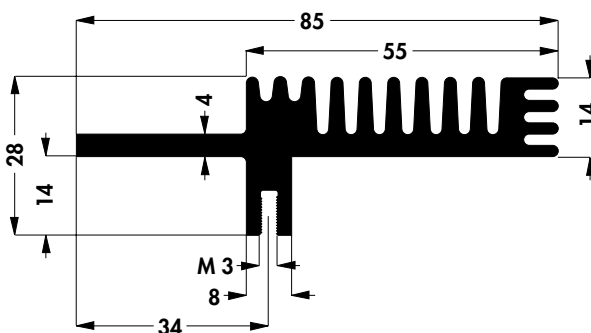

passende Schrauben M 3 → A 76

Art. Nr. SZ M 3 x 8

Bitte beachten: Profilpresste Gewinde: → A 7-2.

matching screws M 3 → A 76

Art. No. SZ M 3 x 8

Please note: Profile threads: → A 7-2.

vis convenables → A 76

Art. n° SZ M 3 x 8

Veillez considérer: Taraudages extrudés: → A 7-2.